

Concrete Cover Spalling Off Load For Confined Beam

*Dr. Nuri Mohamed Elbasha,
Civil Engineering Department
Faculty of Engineering
Zawia University*

Abstract :

In recent years a marked increase in the use of High Strength Concrete (HSC) has been evident in new Libyan construction projects despite the fact that the current design standard, provides no design rules. HSC has been used extensively in civil construction projects world wide because it reduces the cross section and the weight for long construction members.

High strength concrete and high tensile strength steel are used together to increase the load capacity and reduce the beams' cross section. Using these two materials to design over reinforced beams will lead to huge reduction of cost, which is a desirable issue. However, the problem is the lack of ductility, hence such use is not allowed by the current codes of practice.

Avoiding brittle compression failure by using proper confinement, which restrains the lateral expansion, leads to enhancements in the strength and ductility of concrete. Base and Red (1965) showed through limited experimental testing that double helical confinement enhances the strength and ductility of a beam of high tensile longitudinal steel percentage.

There is limited data regarding the strength, concrete cover spalling off, confined concrete strain and ductility for over reinforced HSC helically confined beams. This research provides experimental data to examine the effect of helical pitch and tensile reinforcement ratio on the concrete cover spalling off and displacement ductility for over reinforced HSC helically confined beam.

Based on this, more study and data on the behaviour of confined HSC beams are needed. This paper presents the experimental results of testing eight full-scale beams with 4000 mm length and a cross section of 200 mm in width and 300 mm in depth. The variables in this research are helix pitch and longitudinal reinforcement ratio. The main objective of this paper is to provide experimental data and study the effect of helical pitch and tensile reinforcement ratio on the concrete cover spalling off and displacement ductility for over reinforced HSC helically confined beam.

Helical effectiveness :

Brittle failure (compression failure) could be prevented when the beam is designed as an under reinforced section as recommended by several codes of practice. However, providing longitudinal reinforcement ratio above the maximum allowable longitudinal reinforcement ratio enhances the flexural capacity of the beam but cause a brittle failure (non ductile failure), which is not allowed by code provisions as ductility is an important factor related to human safety. There are different ways for

improving the ductility of concrete in compression such as providing longitudinal compression reinforcement, by using randomly oriented steel fibers, or by installing helical or tie confinement in the compression zone. A review of these different ways to find the most effective way is presented below.

Shah and Rangan (1970) tested 24 groups of beams for comparison of ductility. The test was designed to be under four point loading to ensure failure in the central constant moment zone. This central zone contained closed stirrups of varying volumes, steel fibers of different amounts or compression longitudinal reinforcement of different volumes. The test results showed that the ductility of beam confined using tie confinement was 10 times the ductility of the control beams (without any ductility reinforcement), while the fibers increased ductility 4.5 times and compression steel increased ductility twice of the control beams. This result shows that the tie confinement is more effective than the compression longitudinal reinforcement and steel fiber for enhancing the ductility. Also the beams, which have longitudinal compression reinforcement, suffer from early failure because of the compression reinforcing buckling problem.

Hatanaka and Tanigawa (1992) stated that the lateral pressure produced by a rectangular tie is about 30 to 50 percent of the pressure introduced by a helix. That will be the case for compression concrete in columns or beams. Helices confine the concrete more effectively than rectangular ties as, helices apply a uniform radial stress to the concrete along the concrete member, whereas rectangular ties tend to confine the concrete mainly at the corners. Also the effective area between the ties is reduced, thus using helical confinement in the compression zone of rectangular beams is more effective than rectangular ties. There is a need for extensive experimental research to understand and provide experimental evidences about the benefits and the effectiveness of

providing helical confinement in over reinforced HSC beams. The following experimental program forms part of an ongoing intensive experimental research program.

Experimental program :

The aim of the experimental program in this study is to investigate the behaviour of over-reinforced HSC helically confined beams and determine the effect of helical pitch and tensile reinforcement ratio on the concrete cover spalling off and displacement ductility for over reinforced HSC helically confined beam. In the test program reported herein, a total of eight beams were tested. All eight beams had the same dimensions; generic details of the beams are shown in Figure 1 and Table 1.

The beams were tested under four-point loading regime in the strong floor of the civil engineering laboratory at the University of Wollongong as shown in Figure 2. The displacement-controlled load was applied using 600 kN actuators. The mid span deflection of the beam was measured using linear variable differential transformers (LVDTs). All the data were recorded using Smart System installed on a PC computer.

The alphanumeric characters in the titles of the beams (e.g. A-HP or F-LR) have the following meaning. The first letter presents the alphabetically in order. The two letters (HP) indicate that the only variable is the helical pitch and the (LR) indicate that the only variable is the longitudinal reinforcement ratio.

Analysis of test results:

A summary of the test results is presented in Table 2. However the strains are not presented in this paper. The influence of helical pitch and the influence of longitudinal reinforcement ratio on the concrete cover spalling

off and displacement ductility for over reinforced HSC helically confined beam are presented and discussed in the following two sections.

Influence of helical pitch:

The effect of helical pitch on the concrete cover spalling off and displacement ductility for over reinforced HSC helically confined beam investigated through the results of the five beams, A-HP, B-HP, C-HP, D-HP and E-HP with different helical pitch. Figure 3 shows the relation between the concrete spalling off load versus helix pitch. It is worth noting that the spalling off load increased linearly as the helical spacing increased and the ultimate load decreased as the helical spacing increased. The failure load of beam B-HP was 88% of the spalling off load, the failure load of beam C-HP was 80% of the spalling off load and the failure load of beam D-HP was 65% of the spalling off load. But the failure load of beam A-HP was 110% of the spalling off load. Based on these findings it can be concluded that the spalling off load is directly proportional to the helical pitch and the ultimate load is inversely proportional to the helical pitch.

Table 1 - Summary of beam details

Beam specimen	Helical diameter and pitch, mm	Longitudinal reinforcement steel	Longitudinal reinforcement ratio (ρ) %	Maximum longitudinal reinforcement ratio (ρ_{max}) %	ρ/ρ_{max}
A-HP	12@ 25	4Ø32	6.84	4.64	1.47
B-HP	12@ 50	4Ø32	6.84	4.64	1.47
C- HP	12@ 75	4Ø32	6.84	4.64	1.47
D- HP	12@ 100	4Ø32	6.84	4.64	1.47

Beam specimen	Helical diameter and pitch, mm	Longitudinal reinforcement steel	Longitudinal reinforcement ratio (ρ) %	Maximum longitudinal reinforcement ratio (ρ_{max}) %	ρ/ρ_{max}
E- HP	12@160	4Ø32	6.84	4.64	1.47
F-LR	10@35	4Ø28	5.24	3.68	1.42
G- LR	10@35	5Ø28	6.55	3.68	1.78
H- LR	10@35	6Ø28	7.86	3.68	2.13

Figure 4 shows the load mid-span deflection for the tested beams. From Figure 4 it could be noted that there is a remarkable effect of helical pitch on the displacement ductility. Beams, which have helical pitches of 25, 50, 75 and 100 mm failed in a ductile manner. The level of the ductility depends on helical pitch. The Beam E-HP failed in a brittle mode, as the upper concrete in the compression zone was crushed and the maximum load was 413 kN and then dropped to 150 kN. This drop indicates the effect of confinement is negligible when the spacing is equal to the confinement diameter, which is in agreement with the experimental results by Iyengar et al. (1970) and Martinez et al. (1984).

Displacement ductility index is defined as the ratio of ultimate deflection to the yield deflection Elbasha (2013). Figure 5 shows that the displacement ductility index increases as helical pitch decreases. The yield deflection for beams A-HP, B-HP, C-HP, D-HP and E-HP were 40, 35, 32, 33 and 38 mm, respectively, and the ultimate corresponding deflection were respectively 240, 193, 65, 52 and 38 mm. It could be noted that, there is no considerable difference between the yield deflections for the five beams compared to the ultimate deflection. Hence, it can be concluded that

the deflection ductility index is affected significantly by the ultimate deflection. It could also be concluded that the helical pitch has a significant effect on the ultimate deflection but less significant effect on the yield deflection.

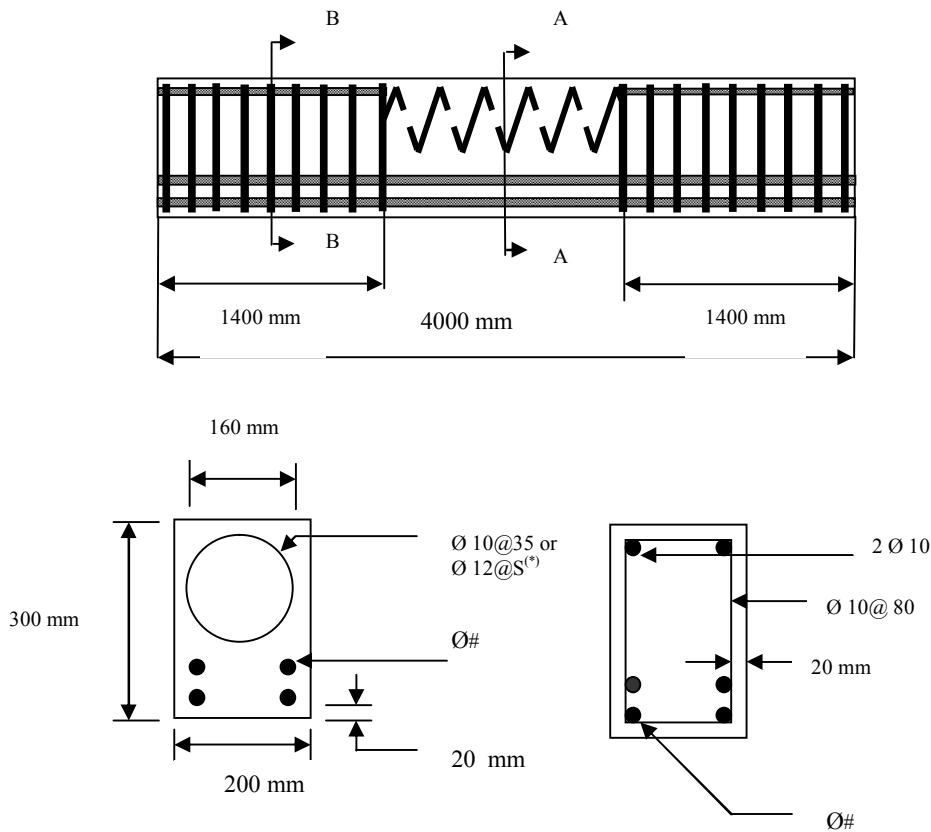

$S^{(*)} = 25, 50, 75, 100$ and 160 mm
 $\text{Ø} = 4 \text{ Ø } 32, 4 \text{ Ø } 28, 5 \text{ Ø } 28$ and $6 \text{ Ø } 28$

SECTION A-A

SECTION B-B

Figure 1. Specimen details



Figure 2. Beam loading

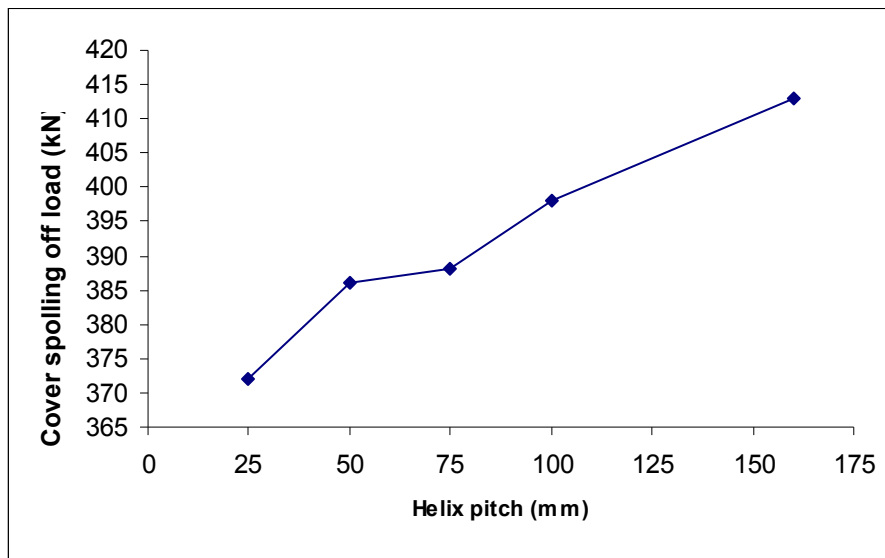

Figure 3. Cover spalling off load versus helix pitch

Table 2 - Summary of beam loads and displacement deflection results

Beam specimen	Concrete compressive strength, MPa	Load at cover spalling off, kN	Failure load, kN	Yield deflection Δ_y , mm	Ultimate deflection Δ_u , mm	Displacement ductility index Δ_u / Δ_y
A-HP	105	372	411	40	240	6
B-HP	105	386	340	35	193	4.6
C- HP	105	388	310	32	65	2
D- HP	105	398	260	33	52	1.6
E- HP	105	413	150	38	38	1
F-LR	95	365	292	39	189	4.8
G- LR	95	344	285	34	180	5.3
H- LR	95	331	329	36	282	7.8

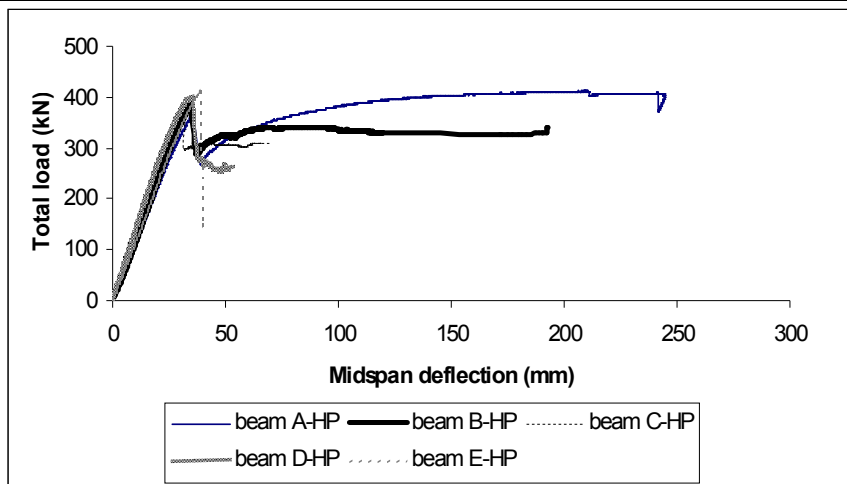

Figure 4. Load-deflection curves for beams with different helix pitch

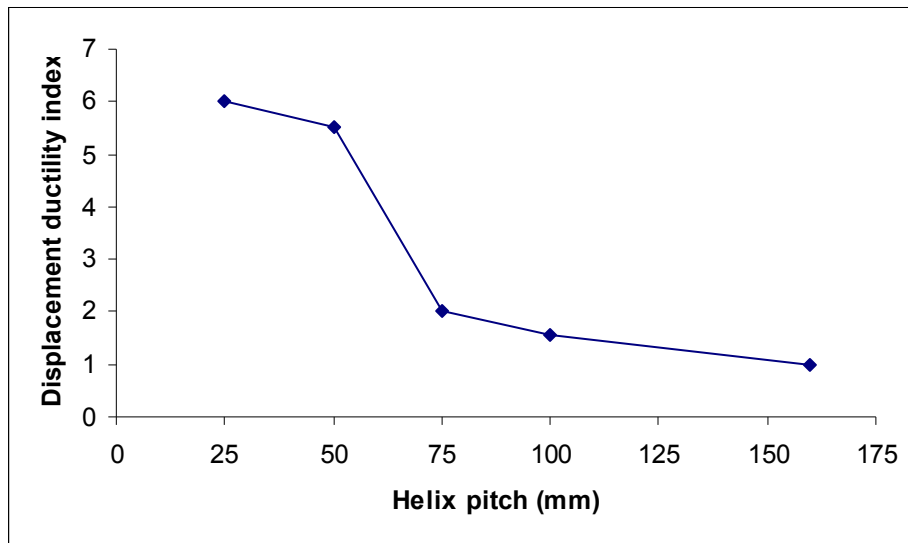

Figure 5. Effect of helix pitch on displacement ductility

Influence of reinforcement ratio :

The effect of tensile reinforcement ratio on the concrete cover spalling off and displacement ductility for over reinforced HSC helically confined beam investigated through the result of the beams F-LR, G-LR and H-LR. Figure 6 shows the load deflection of the three beams, which have the same concrete compressive strength but different longitudinal reinforcement ratio. It is observed that the ultimate deflection increases significantly as the longitudinal reinforcement ratio increases. Bjerkeli et al. (1990) noted that as the longitudinal reinforcement ratio increases as the column member sustained the ultimate load, whereas for columns with lower longitudinal reinforcement ratio the load was decreased immediately after reaching the maximum load. For Beam F-LR which has a concrete compressive strength of 95 MPa and longitudinal reinforcement ratio of 0.00524 the ultimate deflection recorded was 189 mm but for Beam G-LR

where the concrete compressive strength was 95 MPa the ultimate deflection was 180 mm which is 95% of the ultimate deflection of the Beam F-LR. However, Beam H-LR has ultimate deflection 149% of the ultimate deflection of the Beam F-LR. It must be noted that Beam H-LR has an ultimate deflection higher than Beam F-LR even though Beam H-LR has a higher value of ρ/ρ_{\max} . Table 2 shows the ultimate deflection of Beam H-LR. Beams F-LR, G-LR and H-LR have the same concrete compressive strength 95 MPa but different longitudinal reinforcement ratio (ρ) but the maximum longitudinal reinforcement ratio (ρ_{\max}) was the same. (ρ/ρ_{\max}) for Beams F-LR, G-LR and H-LR was 1.42, 1.78 and 2.13, respectively, but the ultimate deflection was 189, 180 and 282 mm, respectively. It could be concluded that for an over reinforced HSC helically confined beams, increasing the longitudinal reinforcement ratio increases significantly the ultimate deflection although the (ρ/ρ_{\max}) has increased.

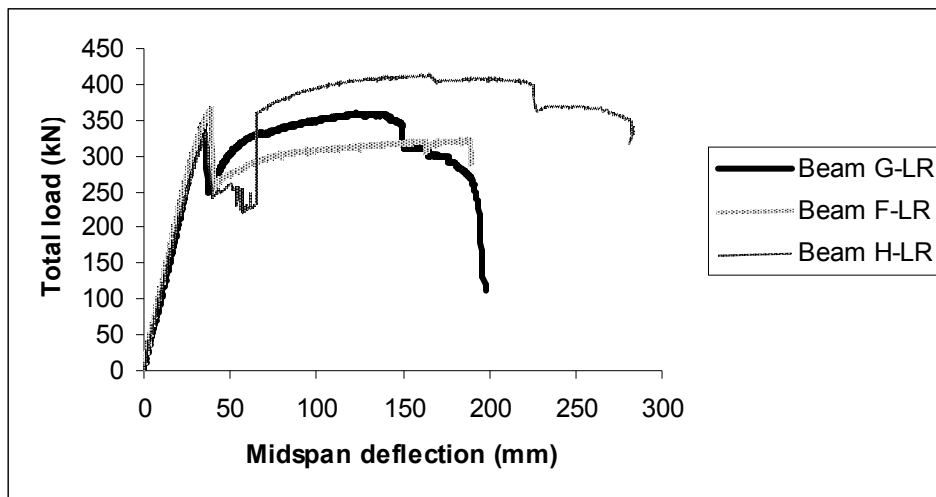

Figure 6. Load- deflection curves for beams that have different longitudinal reinforcement ratio, Beams F-LR, G-LR and H-LR

Figure 7 shows the effect of longitudinal reinforcement ratio on the displacement ductility index. It is noted that as the longitudinal reinforcement ratio increases the displacement ductility index increases. The displacement ductility index for Beams G-LR and H-LR was 110% and 163%, respectively of the displacement ductility index of Beam F-LR, even though Beam H-LR has a higher longitudinal reinforcement ratio it shows a higher displacement ductility index. It was also found a larger amount of long and wide cracking took place in the lower reinforced beams. Figure 8 shows the crack patterns for Beam H-LR and the strong concrete core.

Figure 6 shows that the recorded load at spalling off the concrete cover for Beams F-LR, G-LR and H-LR was 365, 344 and 331 kN, respectively. Also, shows the maximum load for the same Beams was 280, 357 and 412 kN, respectively. It could be concluded that the maximum load is greater than the load at concrete cover spalling off for well confined beams. This is similar conclusion from the experimental results conducted by Cusson and Paultre (1994) that for well confined columns the strength and ductility enhanced by 7% and 56% when the longitudinal reinforcement ratio is increased from 2.2 to 3.6 %. Saatcioglu and Razvi (1993) reported that the strength and ductility of HSC enhanced as the longitudinal reinforcement ratio increases.

Figure 9 shows the effect of longitudinal reinforcement ratio on the concrete cover spalling off load experimentally using three beams with different longitudinal reinforcement ratios and the same concrete compressive strength. Figure 10 shows the concrete cover spalling off phenomenon. The load at spalling off the concrete cover is decreased as the longitudinal reinforcement ratio increased for the three beams which have the same concrete compressive strength of 95 MPa. It could be concluded that the load at spalling off the concrete cover is decreased as the longitudinal reinforcement ratio increases.



Figure 8. Crack patterns for Beam H-LR

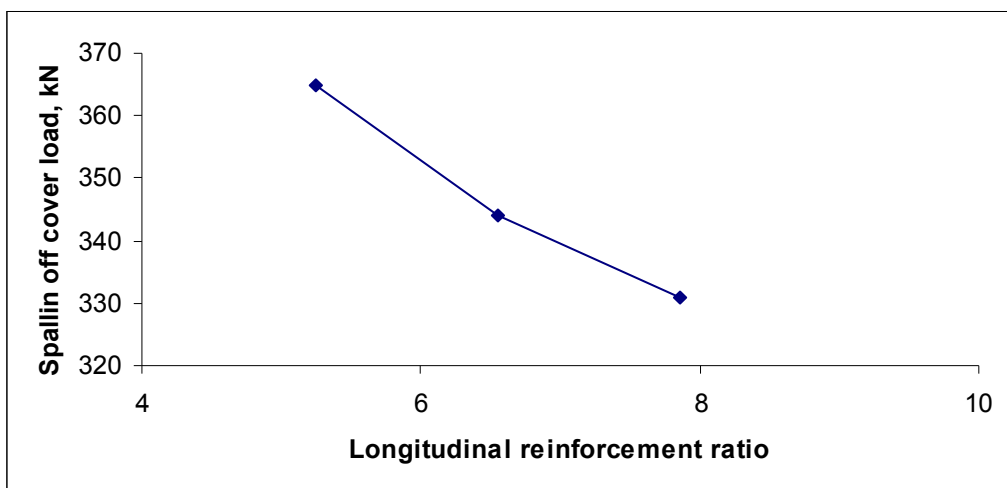

Figure 9. Effect of longitudinal reinforcement ratio on concrete cover spalling off load



Figure 10. Concrete cover spalling off

Conclusion :

The experimental program in this study is to investigate and provide experimental evidence about the significant effect of helical pitch and longitudinal reinforcement ratio on the concrete cover spalling off and displacement ductility for over reinforced HSC helically confined beam. Eight over reinforced HSC beams helically confined were tested. Conclusions can be drawn about the behaviour of these beams with different helical pitches and different longitudinal reinforcement.

The failure behaviour of the beam with helical pitch of 160 mm (equivalent to the core diameter of the beam) was shown to be very brittle in its failure, providing no plateau region in its load deflection. The concrete spalling off was at failure load. The conclusion drawn from testing

the beams is that the confinement effect is negligible when the helical pitch is equal to or greater than the core diameter for helically confined beams.

The failure behaviour of the other beams with helical pitch 25, 50, 75, 100 mm was shown to be ductile and the level of ductility is based on helical pitch. The helices effectively confined the compressive region when the helical pitch was reduced. It is interesting to note that spalling off load increases as the helical pitch increases and the failure load increases as the helical pitch decreases. In other words, spalling off load is directly proportional with the helical pitch and the ultimate load is inversely proportional with the helical pitch.

For over reinforced HSC beams well confined, increasing the longitudinal reinforcement ratio increases significantly the ultimate deflection and then the displacement ductility index although the (ρ/ρ_{\max}) has increased. However, the load at spalling off the concrete cover is decreased as the longitudinal reinforcement ratio increases. The maximum load was higher than the load at spalling off the concrete cover for higher longitudinal reinforcement ratio. Finally, this study has shown that adopting a suitable helix pitch can enhance both the strength and ductility of HSC beams reinforced with high tensile strength steel.

References :

1. *Base GD, Red JB, (1965) Effectiveness of Helical Binding in the Compression Zone of Concrete Beams, Journal of the American Concrete Institute, Proceedings; 62: 763-781*
2. *Bjerkeli L, Tomaszewicz A, Jensen JJ, (1990) Deformation properties and Ductility of High Strength Concrete. Utilization of High Strength concrete –Second International Symposium, SP-ACI, Detroit;121: 215-238*
3. *Cusson D, Paultre P, (1994) High-Strength Concrete Columns Confined by Rectangular Ties. ACI Structural Journal;120:783-804*

4. *Elbasha NM, (2013) High strength reinforced concrete beam and helix confinement. First International Conference on Concrete Sustainability. Tokyo, Japan*
5. *Hatanaka S, Tanigawa Y, (1992) lateral pressure requirements for compressive concrete. Proceedings of 10th World Conference on Earthquake Engineering, Madrid, 2603-2608*
6. *Iyengar KT, Sundra R, Desayi P, Reddy KN, (1970) Stress-Strain Characteristics of Concrete Confined in Steel Binders. Magazine of concrete research; 72:173-184*
7. *Martinez S, Nilson AH, Slate FO, (1984) Spirally Reinforced High-Strength Concrete Columns. ACI Structural Journal; 81:431-442*
8. *Saatcioglu M, Razvi SR, (1993) Behavior of Confined High Strength concrete Columns. Proceedings Structural concrete Conference, Toronto, Ontario, May 19-21; 37-50*
9. *Shah SP, Rangan BV, (1970) Effects of reinforcements on ductility of concrete. Journal of The Structural Division;96:1167-1184*