

# Designing a PLC-Controlled Hydraulic Punching Press

*Hatem Moustafa H Bshena, Mohamed Omar E Abokhder  
Department of Mechanical Engineering, Zawia University*

## **Abstract:**

*Automatic control has become an important part of modern manufacturing and industrial processes. Automatic control provide the necessary tools to obtain the optimal performance of the dynamic systems, improve the quality, lower the cost of production, and increase the production rate. In this paper, a hydraulic punching press system will be designed and controlled via a Programmable logic controller (PLC). The proposed system was simulated using lab-volt virtual laboratory (LVSIM®-HYD) software tool in order to avoid the mistakes that might occur in the actual design; subsequently the punching press system was designed using the Lab-Volt hydraulic training system. This system is*

*consisting of: (1) the PLC is used to control time and regulate the sequences. (2) The Hydraulic system receives and implements the logical commands of PLC. (3) Electrical interfacing circuits which are very important to compromise in the stages of system. In addition, a structure analysis was carried out using an ANSYS software tool in order to apply this design for further applications like stamping process, through creating a pressure guide for the operator.*

***Keywords:** PLC applications, Punching Press system, Automatic control systems, Hydraulic Power.*

## **Introduction.**

There is a consistent requirement for procedure control frameworks in the assembling Businesses to create a superior item more proficiently and easily. This need has led to the development of the automated system. History has demonstrated that the fluid power called hydraulic is considered to be a crucial as modern method of transferring energy [1]. The growing use of hydraulics in the industry comes from the need for fast, low cost means of production with better quality, less waste, and increased power [2]

Hydraulic systems provide many other advantages. A few of these are spark- and burnout-resistance, fine control, and compact size. This means that almost all manufactured products have been formed, treated, or handled by fluid power at some time [3]. Hydraulic drives and controls have become more and more significant due to automation and mechanization. Now a day, a very large amount of modern and powerful machinery is controlled either partly or completely by hydraulics. It is difficult to find steel works, Machine tool applications, Injection moldings machines, Mobile machinery, Handling equipment, Marine application, Civil Engineering, and complicated controls of Dish, Which

are not integrated with extensive hydraulic equipments and PLC control [1]. Hydraulic systems can be controlled manually or electrically. Manual control is good for system functions which do not require constant repetition, or involve a series of interrelated events. Electrical control is more apparent as the complexity and number of system functions increase. With electrical control, flexibility, enhanced performance, and safety are added to the system. Today, most hydraulic systems are controlled electrically through the use of hard-wired electromechanical relays or a programmable logic controller (PLC)[4].

With the hard-wired electromechanical relay systems, relays, timers, and counters are wired together to perform the control task. These systems are often difficult to troubleshoot, expensive to maintain, and require a large amount of space. Modifying the system would require a new layout and rewiring. The components used in the modified system would depend on the new control function [4].

In the PLC-controlled systems, the relays, timers, and counters are replaced by programmable solid-state components and programmed instructions. As in hardwired electromechanical relay systems, the PLC uses relay-type symbology to represent the control circuit. A PLC ladder program is developed, entered, and downloaded to the PLC by means of a computer or hand-held programming terminal. Relays, timers, counters and their associated contacts are now represented by programmed instructions. PLC control should be considered in place of electromechanical relay control when it is desirable to allow the plant floor to communicate more easily with the plant computers, and when it is desirable to reduce the amount of space required on the plant floor by bulky relay banks. Moreover, the PLC takes the advantage over the hard-wired controlled when it is wanted to allow one machine or process to perform multiple tasks by reprogramming the PLC [4].

The purpose of this study was to design a PLC-controlled punching press system. The goal behind using Programmable logic controller approach was due to the widespread using of PLC in the industry. Furthermore, PLC installations added innumerable benefits to the system. Safer and more comfortable working conditions, increased production, higher efficiency, minimal downtime, higher quality products, are only a few examples of the PLC benefits [4].

## **Hydraulic Punching Press System**

A punch press is a machine used to change the shape of metal, specifically to form, stamp or to cut it. As a rule, a bit of metal is gone through the press. The machine clamps down on the metal and cuts, forms or stamps it to a predetermined shape [5].

Punch presses are generally driven by electric engines, and transformation from the turning movement of the drive shaft to reciprocation movement of the slam is affected by a wrench, a switch, or a cam mechanism. Since the power requests are irregular, a flywheel is attached to the drive shaft to store energy during the idling period between strokes of the ram and to convey energy to the shaft during a punching operation; therefore, reducing the needed capacity of the driving motor. *In addition to the electrical driving a press, there is a hydraulic press* [6].

Hydraulic press is a gadget that comprising of a barrel fitted with a sliding piston that applies compel upon a limited fluid, which, thusly, produces a compressive power upon. The fluid is constrained into the barrel by a pump.

The hydraulic press is generally utilized in industry for forming metals and for different errands where a vast power is required. The figure below shows the basic operation principle of punching press system that work under the hydraulic power. These operation sequences

will be used to design, and implement the proposed machine (Punching press system) through using a Lab-volt hydraulic training system [4,7].

### **Working Methodology**

The punching press system consists of a punching cylinder and a positioning cylinder. The positioning cylinder can move metal plates to two punching positions. The machine operation can be explained as follows:

Initially, the positioning cylinder is at the HOME (fully retracted) position, which corresponds to the first punching position. The metal plate is positioned on a roller table and clamped into a place by means of a fixing screw, as Figure (1- a) shows [4]. Secondly, when the operator presses a START pushbutton, the punching cylinder extends and moves the punching head to punch the metal plate with a maximum force of 3200 N (720 lb). After punching the first hole, the punching cylinder is fully retracted, and the positioning cylinder extends and moves the plate to the second punching position, as showing in Figure (1-b). The next step shows that when the positioning cylinder is fully extended, the punching cylinder reciprocates to punch another hole into the plate, as Figure (1- c) shows [4]. Finally, when the punching cylinder is fully retracted, the positioning cylinder retracts and returns the plate to HOME position, and then the punched plate can be removed and another plate can be positioned on the machine.

Pressing a STOP pushbutton at any step of the process causes the punching cylinder to retract immediately, and the positioning cylinder retracts fully as well. This step represents the emergency button that each machine should have to protect operator from any expected risks [4].

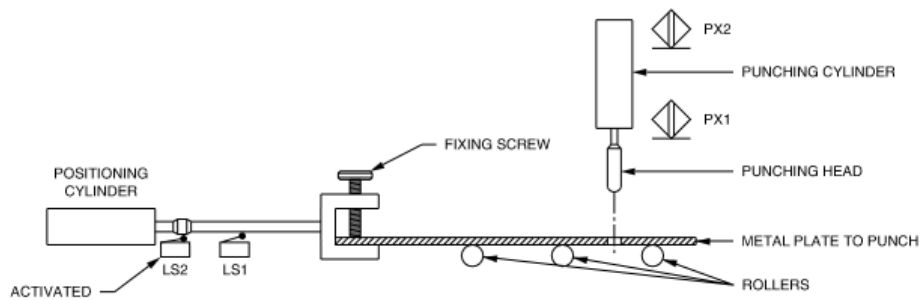

a) Initially, the plate is at the HOME (first punching) position[4].

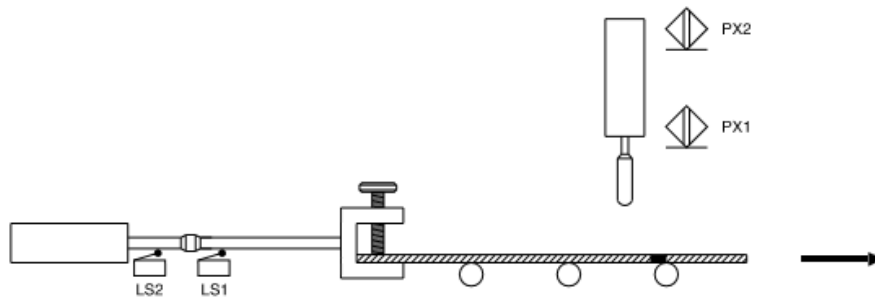

b) First hole has been punched; plate is moved toward the second punching position [4].

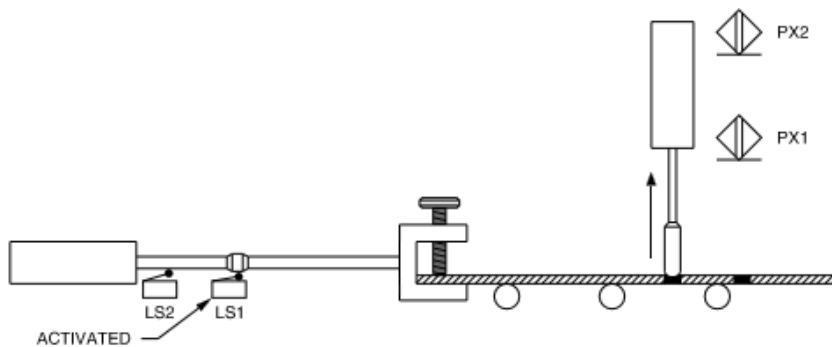

c) Plate is at the second punching position, punching cylinder retracts[4].

Figure (1). PLC-controlled punching press used to punch two holes into metal plates.

## Design of Hydraulic Circuit

Through following the mentioned operation steps of punching press system, and using the knowledge of programming the 1000 Micrlogix PLC through using RSlogix500 software tool, a system control design was accomplished. Moreover, the hydraulic circuit was simulated first using The Lab-Volt Hydraulics Simulation Software (LVSIM®-HYD), and then the actual hydraulic circuit was developed (see figure (2)) in order to combine the hydraulic circuit with the PLC circuit.

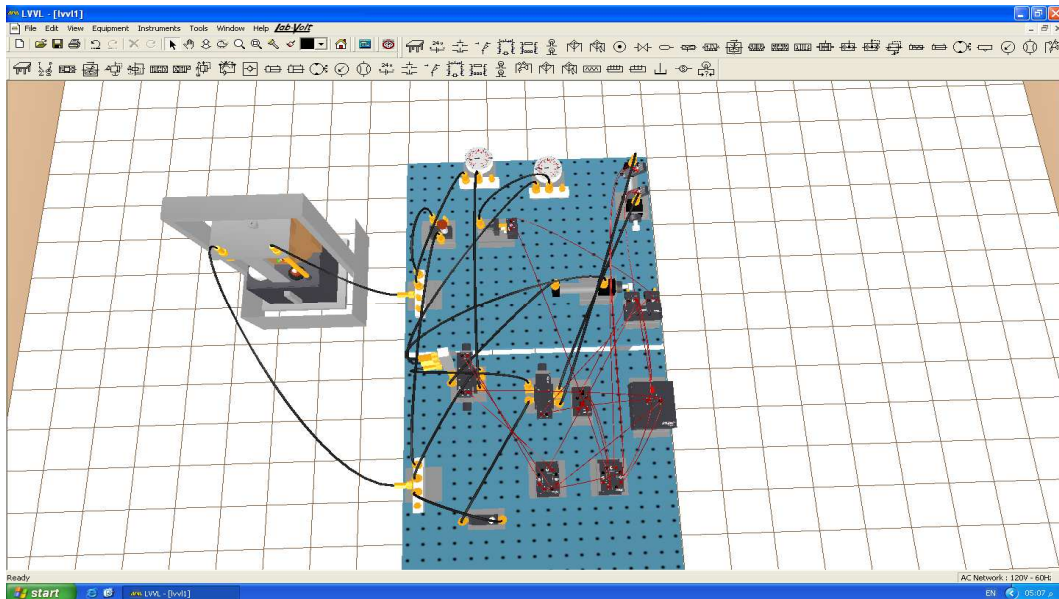

Figure (2) Simulated Hydraulic Circuit of the Punching Press System

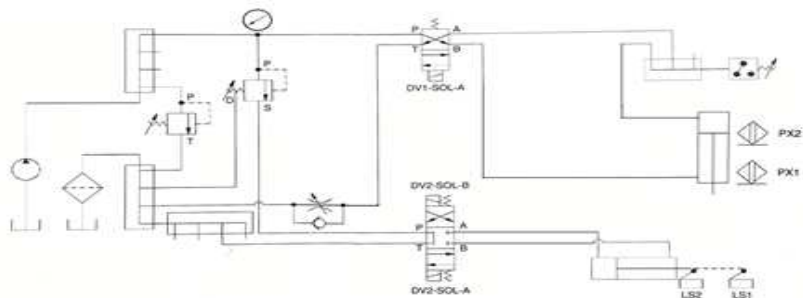

Figure (3) Hydraulic Circuit of the Punching Press System

The hydraulic circuit consists of two cylinders that represent the punching and position cylinder. Two solenoid control valves were used in this circuit. The first valve is single solenoid valve ( DV1), and the second valve is double solenoid valve ( DV2). The positioning cylinder is attached to a mechanical limit switch sensor (LS1 and LS2). Furthermore, the circuit contains two proximity switches sensors (PX1, PX2) attached to the punching cylinder to indicate the fully retracted and fully extended position. A pressure switch sensor (PS), sequence valve, pressure relief valve, and power unite were used to form the hydraulic circuit.

### **Programming:**

The programming language used here is ladder logic. It represents a program by a graphical diagram that is predicated on the circuit diagrams of relay logic hardware. It is used to develop software for programmable logic controllers (PLCs) in industrial control applications. The name is due to programs during this language tally ladders, with 2 vertical rails and a series of horizontal rungs in between them [8,9]. A ladder diagram was designed and drawn according to the sequence of operations as described in the working methodology section. This program was summarized in the algorithm shown below, and the real system was designed and successfully tested in lab using the Lab-Volt hydraulic training system which is showing in figure (4).



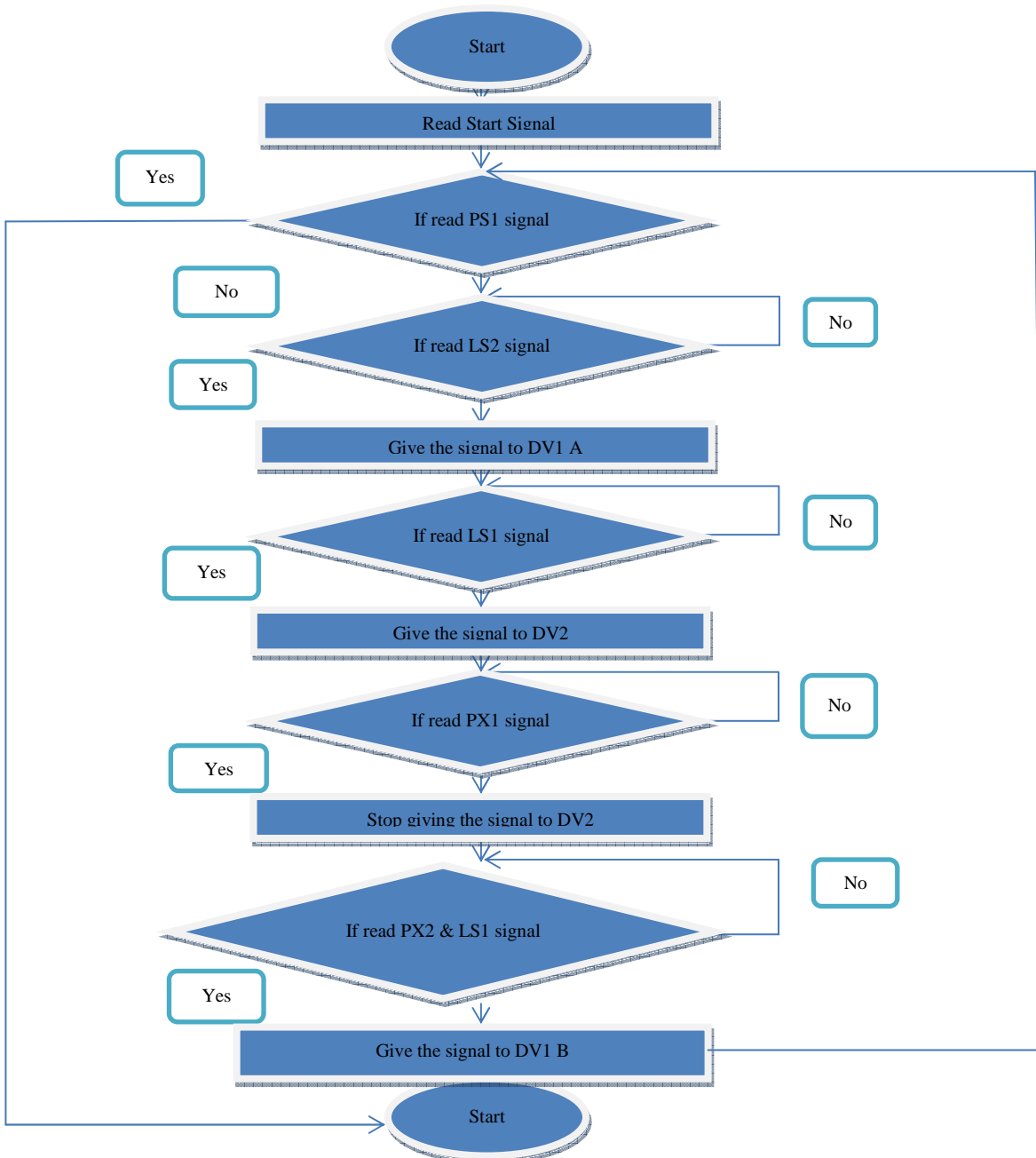

Figure(4): A PLC-controlled Punching Press System Algorithm

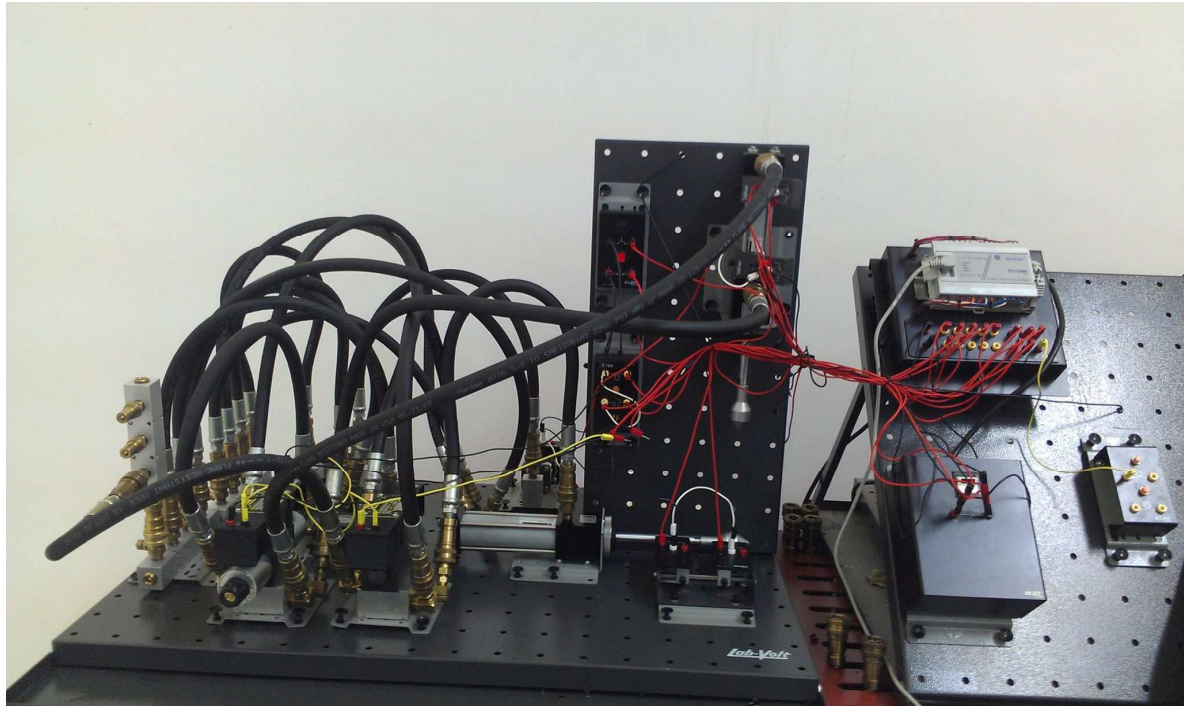

**Figure (5) Actual Design of PLC-controlled Hydraulic Punching Press System**

A detailed description of the operation sequence performed by the PLC program is described in the table (1):

**Table (1) Valves switching sequence**

	Solenoid	SV-feeder	SV_Clamp_ON	SV_Clamp_OFF	SV_PUNCH_ON	SV_PUNCH_OFF
Operation						
Feeding	√					
Clamping			√			
Punching	√				√	
End Punching	√					√
End Clamping				√		

## **Finite Element Analysis :**

The purpose of this analysis was to make pressure guide for the operator in order to avoid any problems may happen to the machine or to the plate due to over load. There are many software tools that can conduct the structure analysis. ANSYS is one of them. ANSYS Structural software tool addresses the distinctive issues of pure structural simulations without the need for further tools. ANSYS offers all the power of nonlinear structural capabilities so as to deliver the highest-quality, and most reliable structural simulation results available [7]. Moreover, ANSYS Structural easily simulates even the biggest and most complicated structures.

In order to accomplish the structural analysis, two most common cases of punching press were selected. Pressing and stamping are the selected cases. In addition, four common materials were selected for the mentioned punching cases. Aluminum alloy, Gray cast Iron, Stain steel iron and Copper alloy with dimensions of 6x6x3 cm. Figure (6) illustrates the dimensions of the testing plate.

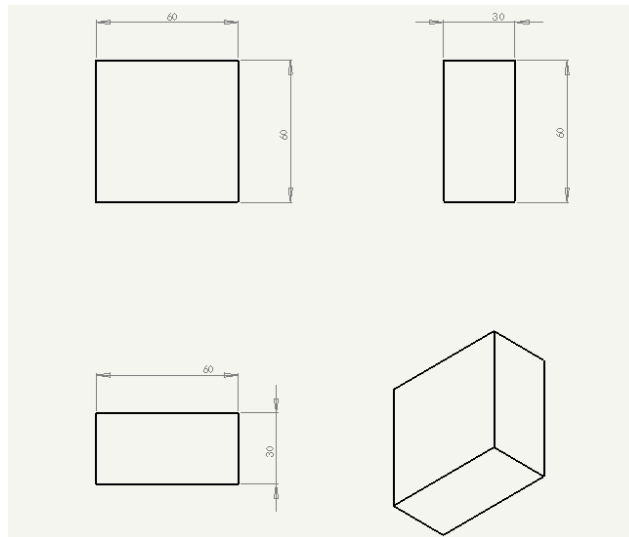

**Figure (6) Solid Work Isometric for the testing Plate**

The structural analyses have been done, and the results are showing in the following figures:

1. Analyses on Aluminum alloy plate

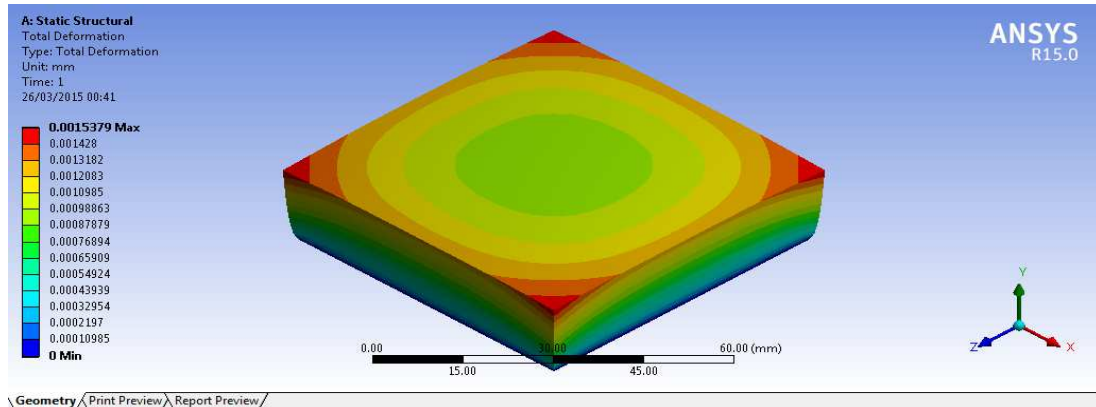

Figure (7) Stamp Case for Aluminum Alloy Plate

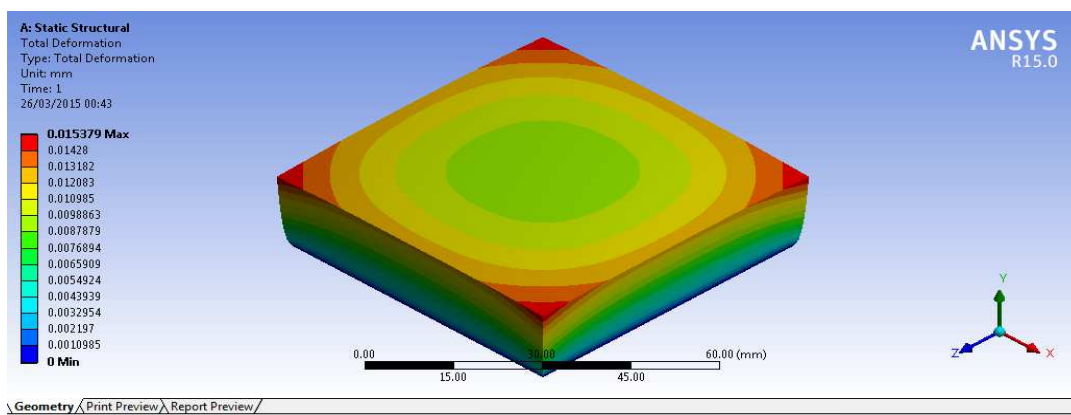
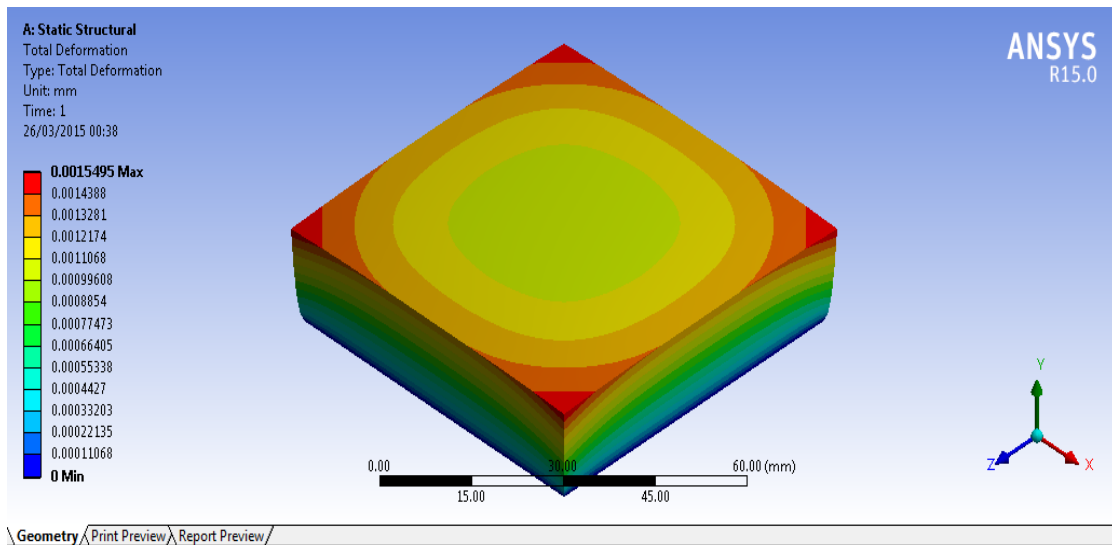
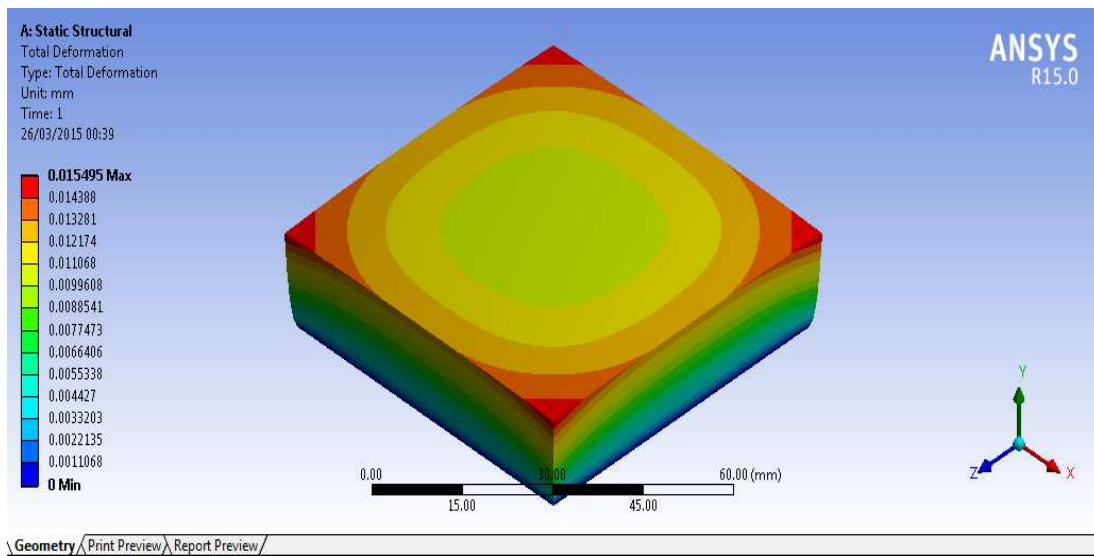

Figure (8) Press Case for Aluminum Alloy Plate

## 2. Analyses on the Gray cast iron plate



**Figure (9) Stamp Case for Gray Cast Iron Plate**



**Figure (10) Press Case for Gray Cast Iron Plate**

### 3. Analyses on Copper alloy plate

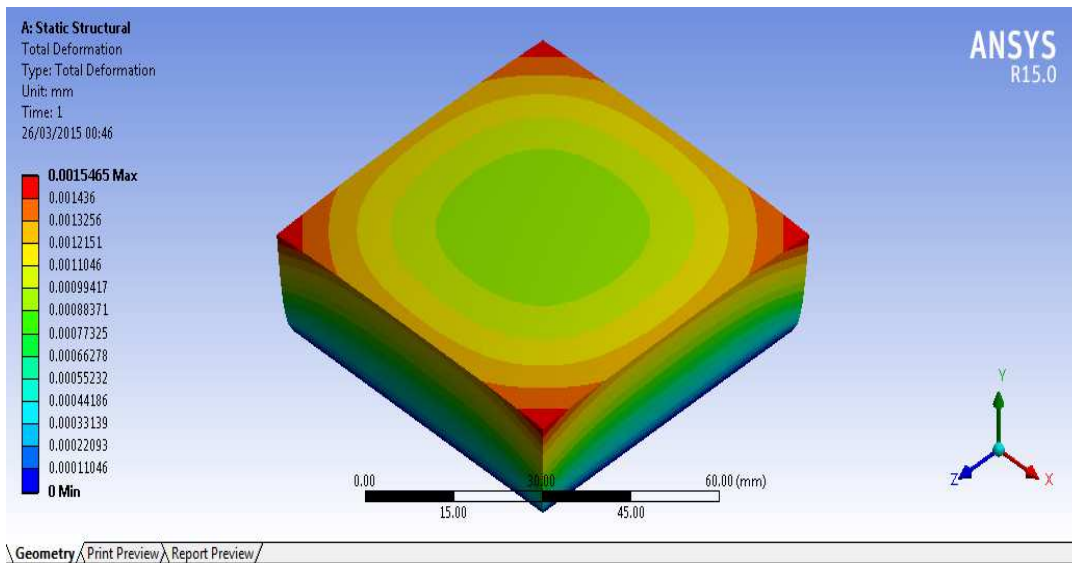

Figure (11) Stamp Case for Copper Alloy Plate

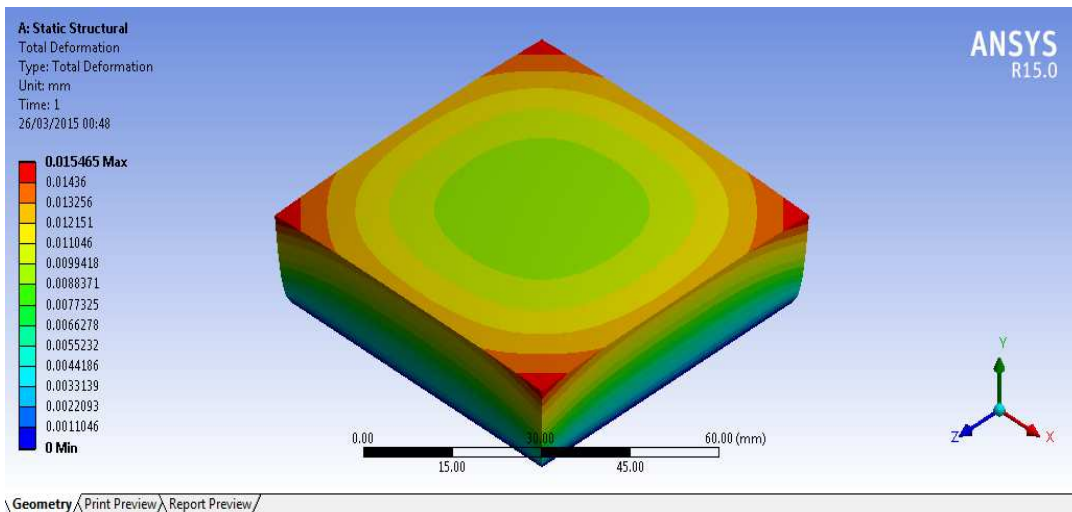

Figure (12) Press Case for Copper Alloy Plate

#### 4. Analyses on Stain Steel Plate

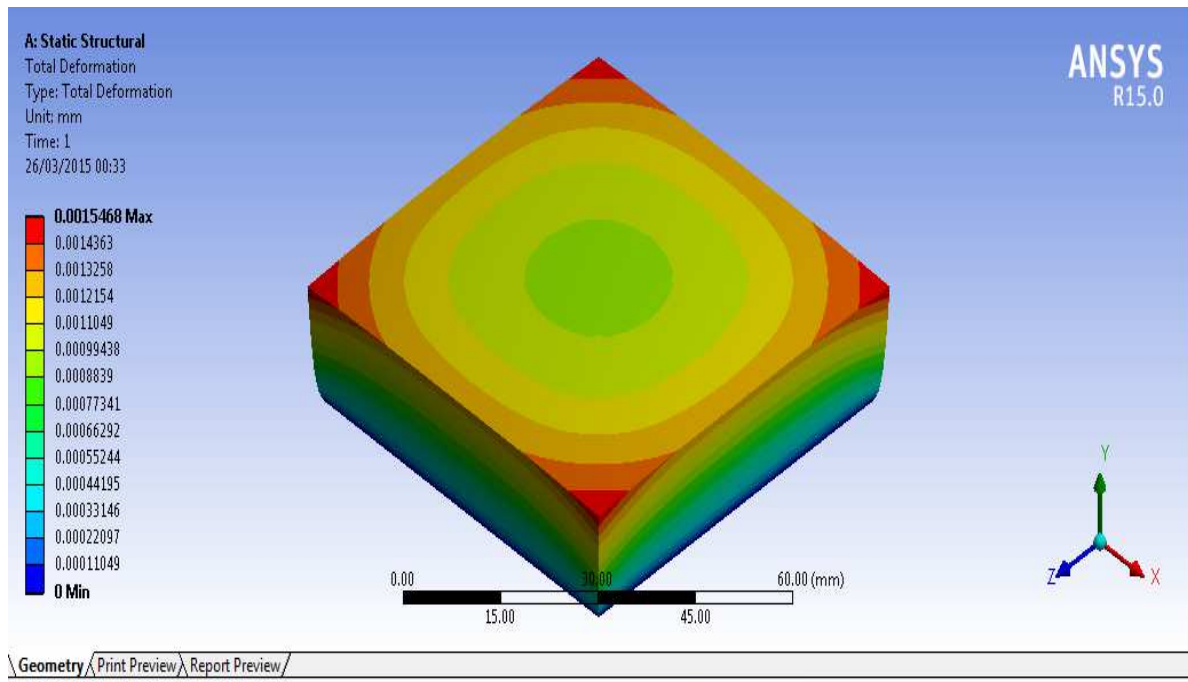

Figure (13) Stamp Case for Stan Steel plate

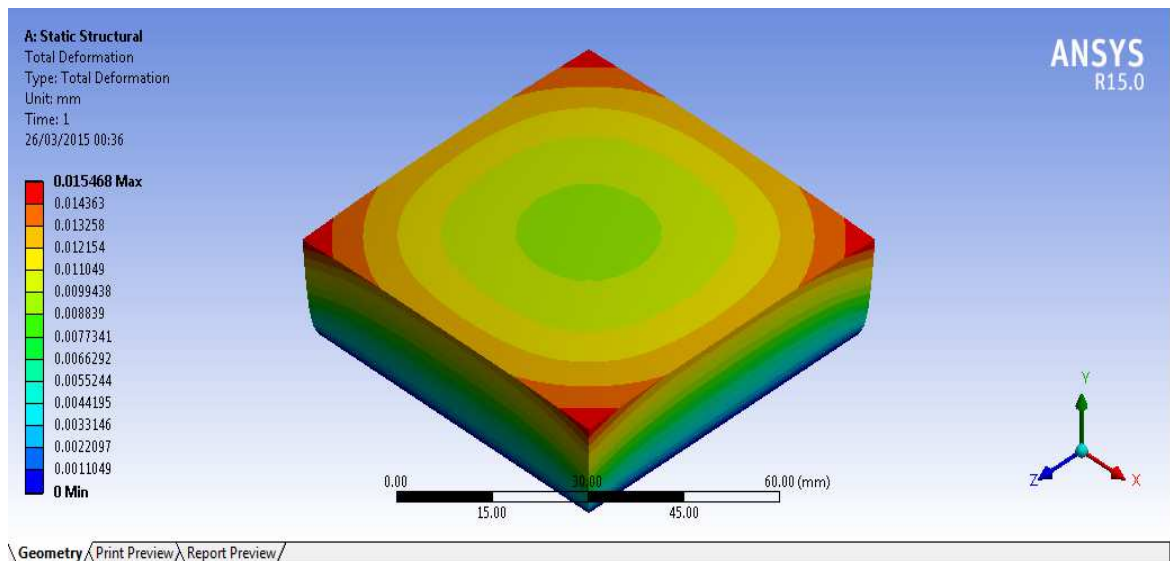

Figure (14) Stamp Case for Stan Steel plate.

The analyses show that the plate in the stamping case is still in the elastic zone at all different materials types, and the deformation does not happen to the plate, and it does not exceed 1.5  $\mu\text{m}$  (Hypothesis). On the other hand, the pressing case is exceeding the elastic zone and it reaches the plastic zone and the total deformation starts from 0.015 as hypothesis said. Based on these results, a pressure operating guide has been created for the operator in order to avoid any damage that might be happened to the machine or to the sample.

Table (2) Determined Operation Pressure

Plate's material	Stamp case (maximum pressure)MPa	Press case (minimum pressure)MPa
<b>Aluminum alloy</b>	<b>4.139</b>	<b>41.395</b>
<b>Gray cast iron</b>	<b>6.765</b>	<b>67.665</b>
<b>Copper alloy</b>	<b>6.385</b>	<b>63.889</b>
<b>Stain steel</b>	<b>11.52</b>	<b>115.2775</b>

### **Conclusion :**

In this paper, a hydraulic design method for a punching press system was explained and successfully tested. Furthermore, Programmable Logic Controllers was used as the controller of the entire framework and the system was successfully controlled with this



approach. In addition, Structural analyses for different materials and different working applications were successfully conducted and an operator pressure guide was developed from those analyses in order to help the machine operator.

### **References:**

1. Oleiwi, M. A., Al-Timimi, A. M., & Ammar, A. (2009). *Design & Simulation of PLC Control and Electro-Hydraulic System for a Punching Machine. Eng. & Tech. Journal* , 27, 13
2. Ltd., The Staff of Lab-Volt. (2009, September 1). *Fluid Power. ELECTRICAL CONTROL OF HYDRAULIC SYSTEMS* .Quebic, Ontario, Canada.
3. Ltd., The Staff of Lab-Volt. (2009, January 1). *Fluid Power. Hydraulics Fundamentals* .Quebic, Ontario, Canada.
4. Ltd., The Staff of Lab-Volt. (2006, October 1). *Fluid Power. Hydraulics Applications – PLC* .Quibec, Ontario, Canada.
5. Eltantawie, M. A. (2011). *DESIGN, MANUFACTURE AND SIMULATE A HYDRAULIC BENDING PRESS. Internatinal Journal of Mechanical Engineering and robotics research* , 9.
6. Munson, B. R., Young, D. F., Okiishi, T. H., & Huebsch, W. W. (2010). *Fundamentals of Fluid Mechanics, Sixth Edition*. Hoboken, NJ: John Wile & sons INC.

7. *US Army Aviation Logistics School. (1994, September). BASIC HYDRAULIC SYSTEMS AND COMPONENTS, EDITION A. Hoopkens, NJ, United state of America .*
8. *Kelaginamane, S., & R, S. D. (2015, January). PLC Based Pneumatic Punching Machine. Journal of Mechanical Engineering and Automation 2015, 5(3B): 76-80 , 6.*
9. *Bolton, W. (2009). Programmable Logic Controllers, Fifth Edition . NJ: Wiley & sons.*